

Direct drive BRUSHLESS DC motors

→ 30 Watts

- Ideal for movement and positioning applications
Adjustable : 4 quadrant variable speed control
- Complete : Brake, 2 channel encoder and integrated EMC filter
 - Compact : High efficiency and starting torque
 - Open : Compatible with Crouzet Millenium II+ logic controller
 - Flexible : 24 V supply allows battery operation



Specifications

	30 Watts
Speed control	0-10 V and PWM
Part numbers	80 140 004
Supply voltage (V)	24 (18 → 28)
No-load characteristics	
Speed of rotation (rpm)	3 100
Absorbed current (A)	0.2
Nominal characteristics	
Speed (rpm)	2 200
Torque (mN.m)	140
Absorbed current (A)	1.9
Maximum characteristics	
Start torque (mN.m)	220
Starting current (A)	3.0
General characteristics	
Insulation class (conforming to IEC 85)	B (120°C)
Casing temperature rise at 40°C ambient max. (°C)	15
Thermal time constant (min)	15
Inertia (g.cm ²)	50
Weight (g)	800
Acoustic pressure at 50 cm (dBA)	40
Service life L10 (h)	20 000
0-10 V speed input characteristics	
Input impedance (kΩ)	10
Full scale speed (rpm)	3 100
PWM speed input characteristics	
Input impedance (kΩ)	10
Level 0 input voltage (V)	< 1.7
Level 1 input voltage (V)	> 3
Frequency range (Hz)	150 → 5 000
Full scale speed (rpm)	3 100
Output characteristics	
Type of output	NPN
Max. current (mA)	50

Product adaptations

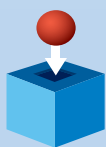

- 2 quadrant speed regulation,
- Motors with hall effect sensors only,
- Adaptations on electronics,
- Special cable lengths,
- Special connectors fitted to the cable.

Curves

Speed/torque

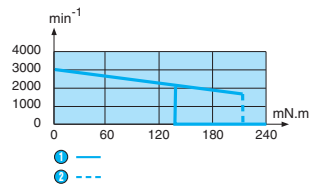

- ① Continuous operation
- ② Cyclic operation

Current/torque

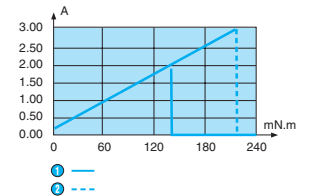

- ① Continuous operation
- ② Cyclic operation

Dimensions

Version IP 54

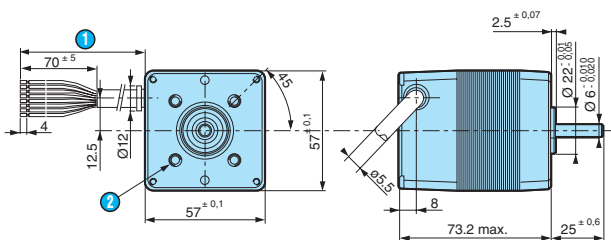

- ① Cable length : 400 ± 10 mm
- ② 4 holes M5 x 0.86 H on $\varnothing 40$ depth 4.5 mm mini

Connections

Marking on motor	Function	Wire colour
*a	Power earth	Black
*a	24 V power supply	Red
	Signal earth	Blue
	On/off input	Green
	Direction input	Yellow
	PWM speed setpoint	Orange
	0-10 V speed setpoint	Brown
*b	12 points/rev encoder output	Purple

1 power cable
AWG24
8 conductors
UL2464

Applications

Examples of encoder output cabling (purple)

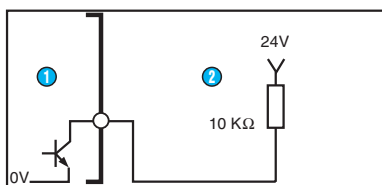

- ① Motor
- ② Resistive load

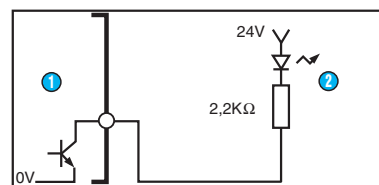

- ① Motor
- ② LED load

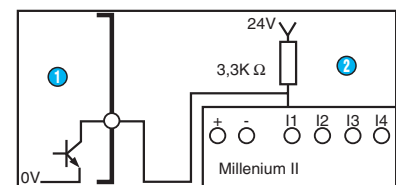

- ① Motor
- ② Millenium II+

User information

- *a) Do not invert the polarities
- *b) Do not short-circuit the encoder output (NPN)
Do not use the motor as a generator

Direct drive BRUSHLESS DC motors

→ 80 Watts

- Ideal for movement and positioning applications
Adjustable : 4 quadrant variable speed control
- Complete : Brake, 2 channel encoder and integrated CEM filter
 - Compact : High efficiency and starting torque
 - Open : Compatible with Crouzet Millenium II+ logic controller
 - Flexible : 24 V supply allows battery operation



Specifications

	80 Watts PWM control	80 Watts 0-10 V control
Speed control	PWM	0-10 V
Part numbers	80 180 001	80 180 002
Supply voltage (V)	24 (18 → 37)	24 (18 → 37)
No-load characteristics		
Speed of rotation (rpm)	4 200	4 200
Absorbed current (A)	0.4	0.4
Nominal characteristics		
Speed (rpm)	3 250	3 250
Torque (mN.m)	240	240
Absorbed current (A)	4.8	4.8
Maximum characteristics		
Start torque (mN.m)	300	300
Starting current (A)	6.0	6.0
General characteristics		
Insulation class (conforming to IEC 85)	B (120°C)	B (120°C)
Casing temperature rise at 40°C ambient max. (°C)	20	20
Thermal time constant (min)	15	15
Inertia (g.cm ²)	105	105
Acoustic pressure at 50 cm (dBA)	50	50
Service life L10 (h)	20 000	20 000
0-10 V speed input characteristics		
Input impedance (kΩ)	-	440
Full scale speed (rpm)	-	4 200
PWM speed input characteristics		
Input impedance (kΩ)	19	-
Level 0 input voltage (V)	< 2.5	-
Level 1 input voltage (V)	> 11.5	-
Frequency range (Hz)	150 → 1000	-
Full scale speed (rpm)	4 200	-
Output characteristics		
Type of output	PNP	PNP
Max. current (mA)	50	50
Weight (g)	1 400	1 400

Product adaptations

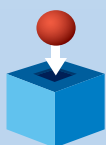

- 2 quadrant speed regulation,
- Motors with hall effect sensors only,
- Adaptations on electronics,
- Special cable lengths,
- Special connectors fitted to the cable.

Curves

Speed/torque

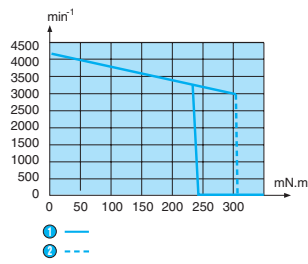

- ① Continuous operation
- ② Cyclic operation

Current/torque

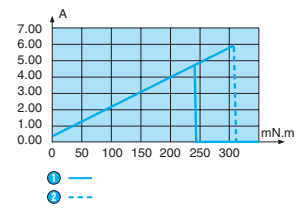

- ① Continuous operation
- ② Cyclic operation

Dimensions

Short version 80 180 0

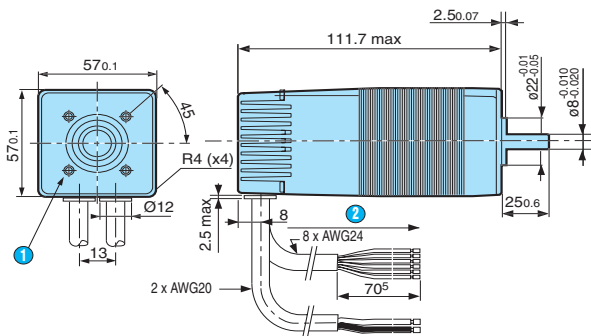

- ① 4 holes M5 x 0.86 H on Ø 40 depth 4.5 mm mini
- ② Cable length : 500 ± 15 mm

Connections

Marking on motor	Function	Wire colour	
*a	Power earth	Black (2nd harness)	1 power cable AWG20
*a	24 V power supply	Brown (2nd harness)	2 conductors UL2464
	Signal earth	Black	
	On/off input	Green	
	Direction input	Yellow	
	Speed setpoint	Orange	1 control cable AWG24
*b	12 points/rev encoder output	Brown	8 conductors UL2464
*b	Encoder direction output	Red	
	Torque limiting setpoint	Blue	
*b	Torque saturation output	Purple	

Applications

Examples of encoder output, direction, torque limit cabling (brown - red - violet)

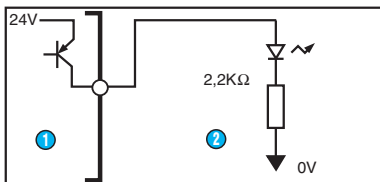

- ① Motor
- ② LED load

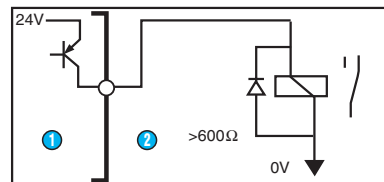

- ① Motor
- ② Relay load

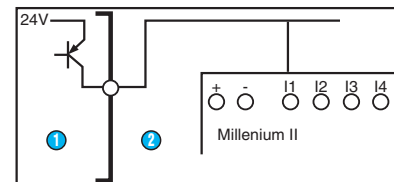

- ① Motor
- ② Millenium II+

User information

- *a) Do not invert the polarities
- *b) Do not short-circuit the encoder output (PNP)
- Do not use the motor as a generator