

# Motomate - Brushless motor with integrated logic controller

## → Motomate 80 watts

- Movement control for simple mechanisms
- All-in-one solution for quick integration
- Compact with high performance
- Intuitive programming with graphical function blocks
- Adapted for severe environments



### Specifications

Type	Ratio	Max. speed (RPM)	Available torque (N.m)	Code
Motor direct drive	-	3 250	0.2	80 080 005
Right angle gearbox	5	650	1	80 081 001
	10	325	1.7	80 081 002
	20	163	2.9	80 081 003
	30	108	3.5	80 081 004
	50	65	3.4	80 081 006
Planetary gearboxes	5	650	1	80 089 704
	27	120	4.5	80 089 705
	139	23	20	80 089 706

### Accessories

Designation Code	Designation Code
Programming cable PC/Motomate - serial port	79 294 791
Programming cable PC/Motomate - USB	79 294 790
Programming software on CD ROM	79 294 792

### General characteristics

General characteristics	
Supply voltage (V)	24 (20 → 37)
Max. current (A)	6
Immunity from micro power cuts (ms)	1
Operating temperature (°C)	-20 → +40
Protection index	IP 54
Programming	
Inputs / outputs	4I/4/O
Programming method	Function blocks / SFC
Program size	128
Program memory	Flash EEPROM
Program cycle time (ms)	10
Real-time clock	No
Logic inputs	
Max. number	4 (I1 → I4)
Input impedance (kΩ)	> 10
Logic 1 voltage threshold (V)	> 15
Logic 0 voltage threshold (V)	< 5
Response time (ms)	10
High speed inputs	
Max. number	2 (I1 → I2)
Max. frequency (KHz)	4
Analogue input	
Max. number	2 (I3 → I4)
Measurement range	0-10 VDC
Resolution	8 bits
Accuracy	± 5 %
Logic outputs / PWM	
Max. number	4 (O1 → O4)
Type of output	PNP
Insulation	No
Max. current (mA)	250
Leakage current (mA)	< 0.1
Response time (ms)	10
PWM frequency (KHz)	0.11 → 1.8
PWM precision at 120 Hz	5 %

## Dimensions

### Direct drive

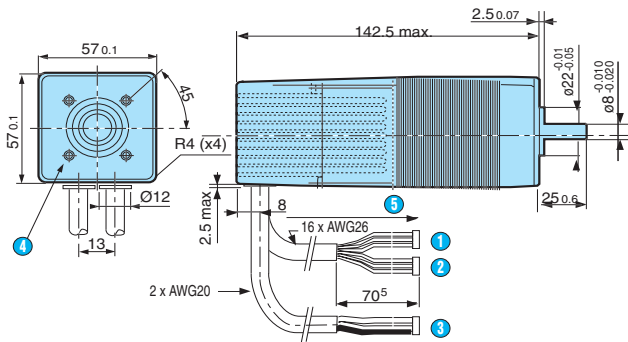

- ① Connector 6 way Programming motomate
- ② Connector 10 way Inputs/outputs motomate
- ③ Connector 2 way Power supply
- ④ 4 holes M5 at 90° on Ø 40 depth 4.5 mini
- ⑤ Cable length : 500 ± 15 mm

### Right angle gearbox

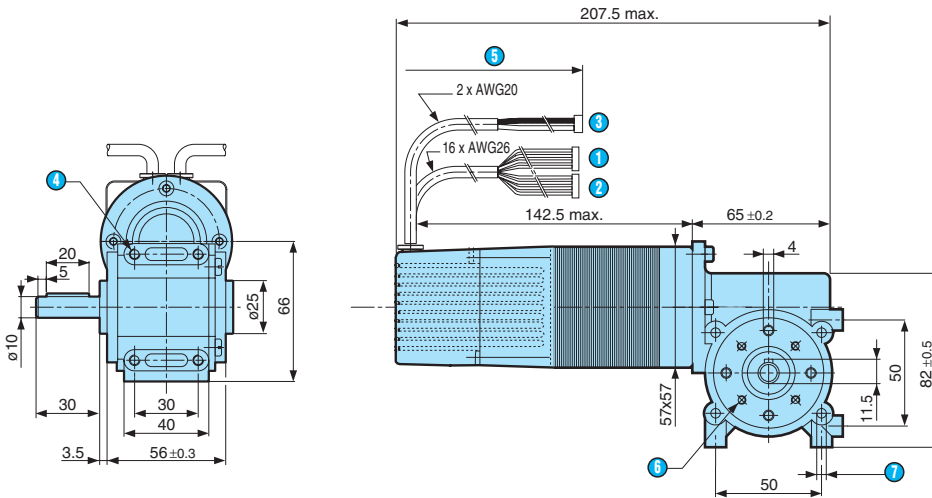

- ① Connector 6 way Programming motomate
- ② Connector 10 way Inputs/outputs motomate
- ③ Connector 2 way Power supply
- ④ 4 x M5 depth 8 mm
- ⑤ Cable length 500 ± 5 mm
- ⑥ 4 x M4 on Ø 36 depth 8 mm
- ⑦ 4 x M5 depth 8 mm



Radial load max. = 150 N  
Axial load max. = 100 N

### Planetary gearboxes

- ① Connector 6 way Programming motomate
- ② Connector 10 way Inputs/outputs motomate
- ③ Connector 2 way Power supply
- ④ 4 holes M6 on Ø 65 depth 12 mm
- ⑤ Fixing hole M6 x 16
- ⑥ Cable length : 500 ± 15 mm
- ⑦ Key A6 x 6 x 28 according to DIN 6885

L2 Ratio 5 : 212.8 mm max.  
L2 Ratio 27 : 234.7 mm max.  
L2 Ratio 139 : 256.8 mm max.  
Radial load max. = 200/300/500 N  
Axial load max. = 80/120/200 N  
(according to no. of stages)

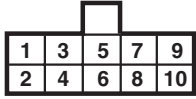
## Connections

Comment	Legend	Pin N°	Wire color	Motomate connector	Application connector
*a	+24V	1	Brown	1 power connector Molex 2-way (Ref. 51144-0200)	PCB side top view  Ref. 53520-0220
*a	GND	2	Black		
*b	IN1	1	Brown	1 I/O connector Molex 10-way 2.54 mm spacing (Ref. 90142-0010)	PCB side top view  Ref. 90130-1110
*b	OUT1	2	Blue		
	IN2	3	Orange		
*b	OUT2	4	Purple		
	IN3	5	Yellow		
*b	OUT3	6	Grey		
	IN4	7	Green		
*b	OUT4	8	White		
*a	GND	9	Black	1 programming connector Molex 6-way 2.54 mm spacing (Ref. 90142-0006)	PCB side top view  Ref. 90130-1106
*a	+24V	10	Red		
*a	+5V	1	White-Red		
*a	GND	2	White-Black		
	SCL	3	White-Yellow		
	SDA	4	White-Green		
	RX	5	White-Brown		
	TX	6	White-Orange		

## Applications

### Examples of input connections

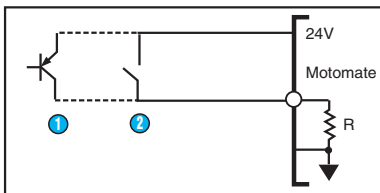

- 1 Sensor output PNP  
or  
2 Contact

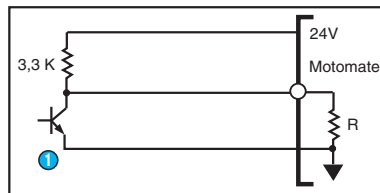

- 1 Sensor output NPN

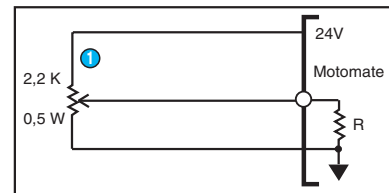

- 1 Potentiometer

### Example of output connections

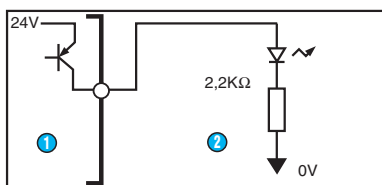

- 1 Motor  
2 Load LED

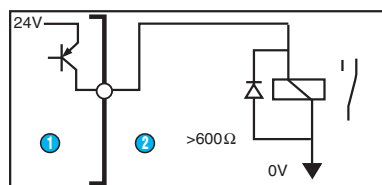

- 1 Motor  
2 Load relay

## Product adaptations

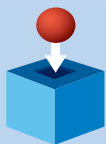

- Special output shaft
- Special supply voltage
- Special cable length
- Customised electronics
- Special connectors
- Special gear ratios
- Special pinion materials
- Special mounting plate

## User information

- \*a) Never reverse the polarity of the supply
- \*b) Do not short-circuit the outputs O1 to O4 to earth
  - Do not use the motor as a generator
  - For more details on the geared motors, consult the brushless catalogue