

Electro-Permanent-Magnet-Clamping-Plate

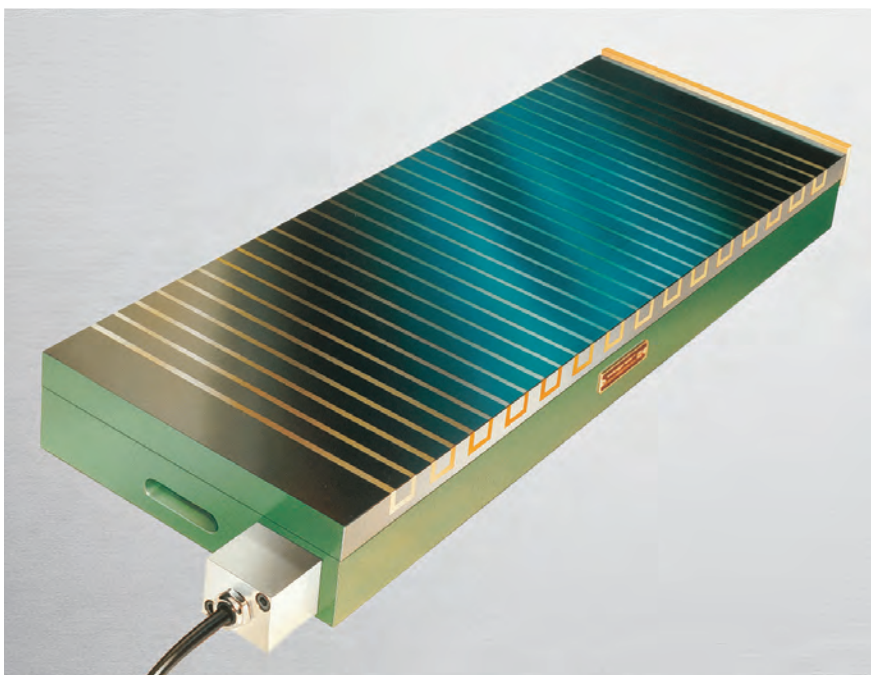

Our electro permanent magnet clamping plate type 1120, with full-width transversal pole spacing features real polarity switch from pole to pole. This achieves a uniform holding force across the entire pole surface of the magnet and clamping surface of the workpiece.

In pole distance "p", the steel poles are separated by brass elements, to achieve alternate rows of north and south poles. We supply type 1120 with standard pole spacing of 11, 13, 18 and 25 mm. Other pole spacing can be ordered specially.

Magnetic holding force is activated as soon as a magnetized workpiece passes through at least one north and south pole. Similarly, this full-width pole spacing enables a lateral fixing to the longitudinal side of the pole plate. Holding bars on the long sides

must be made from non-magnetic material to avoid the possibility of a magnetic short circuit.

The electro permanent magnet clamping plates combine the holding force of permanent magnets with the advantage of switching possibilities associated with an electrical system. This provides all the prerequisites for precision, safety and operating comfort.

During an operation the power feed is interrupted so that no heat is generated by the activated magnets. This eliminates any potential precision problems caused by temperature fluctuations. Switching operations are triggered by a short current pulse. The homogenous construction design of the magnet system and the pole plate offers high precision.

In the event of a power failure, the active clamping plate retains full holding force which guarantees operational safety. In addition, the power feed can be disconnected from the magnets after the current pulse has been triggered. The magnet holding the workpiece can be used in several stations (pallet exchange system) without a current supply.

Design:

- Protection class IP 65
- Magnet operating time: 100 %

Delivery includes:

- Holding bar on the front
- 1.5 m cable
- Clamping shoes

Electrical connection via:

Electronic pole-reversal control units.

These devices, designed especially for controlling clamping magnets, function to facilitate the power supply and simultaneously as demagnetisation devices. A microprocessor controls and monitors all functions and offers optimal switching comfort with numerous control and monitoring functions. The adhesive force is adjustable in up to 16 stages. In addition, these pole-reversal control units also allow additional configuration of parameters and optimised settings. All device types offer particularly impressive shifting dynamics.

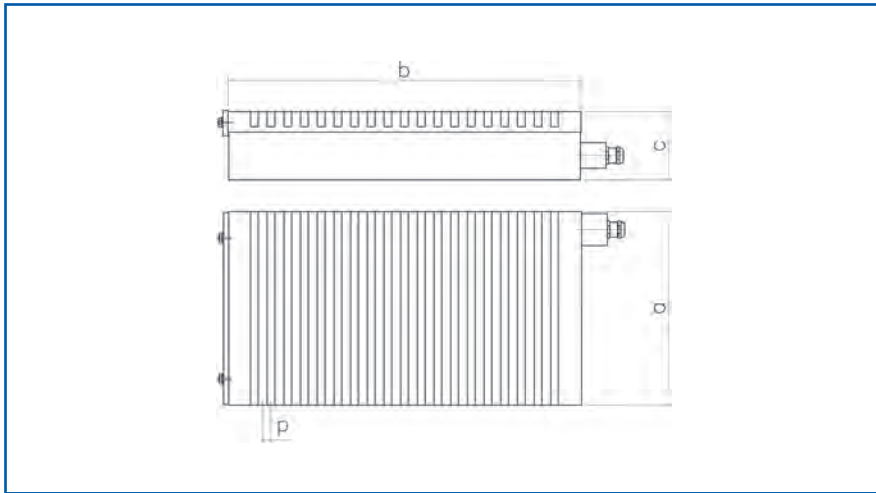

Electro-Permanent-Magnet-Clamping-Plates

Type 1120

with full-width transversal pole spacing

Characteristics:

- Highest level of precision –
- Activated magnet remains cold.
- Highest level of safety –
- Holding force even after power failure.
- Energy-conscious –
- Power used only for short pulses

Dimensions and technical data:

Type	Width a [mm]	Length b [mm]	Height c [mm]	Pole space p [mm]	Weight [kg]	Connection value Pole-reversal control unit [V/A]*
1120-10/30	102	302	80	11-13-18	17	210/10
1120-10/40	102	402	80	11-13-18	23	210/10
1120-15/30	152	302	80	11-13-18	26	210/10
1120-15/40	152	402	80	11-13-18	34	210/10
1120-17.5/45	177	452	80	11-13-18	45	210/10
1120-17.5/50	177	502	80	11-13-18	50	210/10
1120-20/40	202	402	80	11-13-18	45	210/10
1120-20/60	202	602	80	11-13-18	68	210/10
1120-20/80	202	802	80	11-13-18	91	210/30
1120-20/100	202	1002	80	11-13-18	113	210/30
1120-30/60	302	602	80	11-13-18-25	102	210/10
1120-30/80	302	802	80	11-13-18-25	136	210/30
1120-30/100	302	1002	80	11-13-18-25	169	210/30
1120-30/150	302	1502	80	11-13-18-25	254	210/30
1120-40/80	402	802	80	11-13-18-25	181	210/10
1120-40/100	402	1002	80	11-13-18-25	226	210/30
1120-40/150	402	1502	80	11-13-18-25	338	210/30
1120-50/100	502	1002	80	11-13-18-25	282	360/30
1120-50/150	502	1502	80	11-13-18-25	422	360/30
1120-50/200	502	2002	80	11-13-18-25	563	360/30
1120-60/100	602	1002	91	11-13-18-25	384	360/30
1120-60/150	602	1502	91	11-13-18-25	576	360/30
1120-60/200	602	2002	91	11-13-18-25	768	360/30
1120-70/100	702	1002	91	11-13-18-25	448	360/30
1120-70/150	702	1502	91	11-13-18-25	672	360/30
1120-70/200	702	2002	91	11-13-18-25	895	360/30

Other dimensions and pole spacings are available upon request

* = 210 V d.c. variants are also available with 360 V d.c. nominal voltage